

Motion Intelligence

advanced motion control technology for machine designers

Issue 4, November 2002:

- Applications: - flow wrapping
- flatbed cutting
- coil winding
- Motion control trends
- Reducing motion costs
- Easy linear motor upgrades
- Sourcing NEMA motors

Series II - definitely not a 'me too'

Baldor motion controller and servo drive users will have noticed a new Roman 'II' appended to our product names. This denotes an upgrade with a difference, which is delivering new levels of flexibility to our customers. Our Mint software development environment already offers a common API for all of Baldor's wide range of motion control hardware. Series II takes the proposition a step further, by implementing common hardware standards which make it more cost effective to configure equipment and machines for different applications, and simplify purchasing and stocking requirements. *Continued on page 5.*

Reducing motion costs - 4 (and a bit) tips...

The recession in machinery markets is forcing many OEMs to extend equipment lifecycles, with design improvement efforts focused on cost reduction. What are the options? David Greensmith looks at four common techniques. *Continued on page 2.*

Cost reduction strategy	Benefits	Savings
Using motion controller for I/O handling as well	Eliminate need for PLC	Cost of low-end PLC, & cabling etc
Installation of 'intelligent' drives	Replace 2 boxes with 1 (& improve modularity)	~30% hardware, reduced assembly labor & space
Interconnection of I/O and HMIs using fieldbus	Simpler cabling	Less cabling, reduced assembly time
Pre-written software	Shorter development	Man-weeks of effort

Flow-wrapper upgrade speeded by multi-tasking software

Multi-tasking facilities in the Mint motion language helped Premier Packaging to upgrade three wrapping/cartoning machines very rapidly, for one of the world's leading chocolate manufacturers. The mechanical-based machines were being converted to electronic control supporting software-based reconfiguration, to introduce flow wrapping in place of a foil wrapper and paper label. The project was extremely time sensitive, and Premier Packaging refurbished the machines in around 4 months, imposing an even tighter schedule on its sub-contractor Baldor. *Continues p6.*

- Application:**
Multi-axis handling/packaging system
- Motion controller:**
NextMove-BX, MintMT software
- Key design advantages:**
Multi-tasking for speedy development
One card solution for servo axes & actuator/sensor I/O
'Canned' software for key tasks and easy axis synchronization

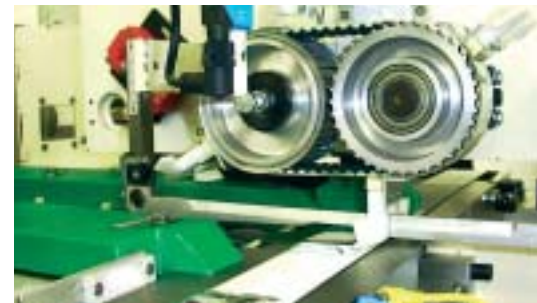

One of the tasks controlled: flow-wrapped chocolate bars are swept through 90° by a 'paddle' into a flighted conveyor which takes them onto the cartoning process.



Reducing motion costs - 4 (and a bit) tips...

continued from page 1:

PLC elimination. Many motion controllers come with enough I/O capability for the required sensing/actuating and safety I/O, and when machine builders decide to exploit that capability, savings can be significant. There's a dichotomy in the motion control market between companies who use PLCs, and those that employ dedicated motion controllers. One common opportunity for gain is when machine builders convert from mechanical motion to electronic controls (for greater speed, flexibility, and less maintenance). They may have used a low-end PLC on the machine to handle the basic logic and interlock operations, and often want to retain it for familiarity reasons (despite adding a motion controller into the equation which could save the cost of a low-end PLC, plus wiring and integration - as well as reduced power requirements). Another situation where this kind of gain becomes obvious is when OEMs have used PLCs for motion control, but try to enhance productivity by implementing more sophisticated motion - say multi-axis interpolation. This sort of functionality tends to be beyond low-to-mid range PLCs - forcing users to upgrade to a top-of-the-line unit which can be an order of magnitude more expensive. Motion controllers invariably offer hardware savings in such cases, which can be of the order of 30% for a 4-axis system. It should also be noted that many PLC vendors charge for motion programming software, and for any PC hosted elements - which adds significant cost into the equation (Mint and PC hosted elements are provided free).

Intelligent drives. A method of reducing system costs currently gaining widespread support is 'intelligent drives'. These are usually single-axis drives with an integral motion controller. Hardware savings of the order of 30% are typical, but they also add savings in terms of space and integration costs - because they eliminate the need for two boxes (actually, three, if you use a motion controller's I/O for PLC replacement), with all the associated costs stemming

LEFT: Traditional PLC plus motion-controller (MC) solution:

- separate PLC and motion control
- standard velocity/current control drives
- complex wiring scheme
- three software tools/programming functions

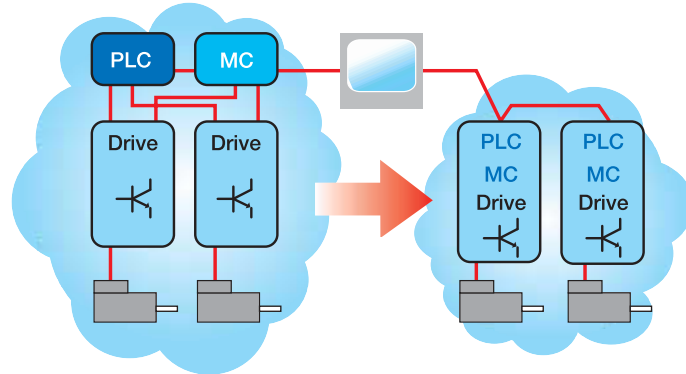

RIGHT: Intelligent drive based system (integrated PLC/motion controller):

- reduced cabling
- fewer system parts/increased reliability, reduced power consumption
- lower cost
- reduced panel space, potential for distributed panels (local to axis mechanics)
- single programming tool, shorter set-up/commissioning time
- (fieldbus) peer-to-peer communications & expandable I/O
- scalability/modularity

from the greater real estate required, and the labor and parts needed to interconnect and install. Baldor offers a considerable range in this area from single- to multi-axis modules and has seen this approach growing at double- and triple-digit rates in the last couple of years. A spin-off (and an additional cost saving measure) is support for the 'modular' design principles that many machine builders employ to simplify construction of a machine range (see below).

Modular design (a brief intro). Too huge a subject to clarify in a couple of lines, but the I/O and autonomous control capabilities of intelligent drives such as MintDrive make it simple to enhance the modularity of motion control systems - so that you can add a drive later without major system modification/reconfiguration for example. Of course, a modular design approach confers many other advantages. It allows machines to be built and tested in discrete sections for example, so that final assembly can take place at the customer's location, saving time and cost.

Fieldbuses. Lastly, in terms of hardware savings, fieldbus use is now a pronounced trend. Virtually every motion controller that Baldor now ships includes fieldbus connectivity - which is usually employed for reducing wiring on the machine, to link to I/O and man-machine interfaces, etc. The savings here are highly machine-dependant and difficult to quantify but are typically at

least a few percent of the motion control system costs, and a more substantial proportion of the assembly labor costs to build the machine. These savings will rise as users shift towards the use of digital connections for drives in place of $\pm 10V$ interfacing. The more complex the machine, the greater the savings typically.

Pre-written motion functions.

Development time is one area where cost savings can be most significant. But it's also subject to considerable marketing 'hype' - making it extremely difficult to quantify the gains. However, there is one aspect that is relatively easy to evaluate and compare: the availability of ready-to-use/adapt motion functions. This is an increasing trend that is providing ready-to-run programs for common motion applications (e.g. feed to length, flying shear). If such software is available, you can easily estimate savings of weeks of development time. This is an intrinsic feature of Mint because of its keyword-based approach, and Baldor continues to add more single-command 'applications' every year, as well as commands for complex motion functions (for example, "FOLLOW.0 =2" configures axis 0 to follow the master encoder (electronic gearing) at a ratio of 2:1).

David Greensmith is international business development manager at Baldor's motion control HQ in the UK, and may be contacted via david.greensmith@baldor.co.uk

Motor manufacturing breakthrough exploits flexibility of PCI controllers

Motion controllers compatible with Mint software are at the heart of what is believed to be the most advanced automation ever produced for electric motor manufacturing. Developed by Alliance Winding for Baldor, the machine automates virtually the entire motor manufacturing process from coil winding and welding stator laminations, to assembly, test and fitting of outer product packaging. It is capable of producing finished assemblies every 20 seconds to programmed specifications.

The machine provides total manufacturing flexibility, allowing Baldor to produce custom motors in very small batches. The only human intervention required is to replenish materials, and to attach the connection leads.

In all, 78 axes of motion and over 200 motors are employed to automate the processes. Mint motion controllers were chosen for the underlying real-time control capability required to implement this application. These controllers allowed Alliance Winding to divide the complex motion control system into loosely-coupled, semi-autonomous sub-systems which control the functions performed at each stage, initiate actions in response to I/O events, all under the supervisory control of a host PC running a Visual Basic user interface.

This distributed architecture was

made possible by the ability of the NextMove PCIbus cards to store and execute embedded motion control programs locally, using the interpreter-style capability of the Mint embedded system. The card's onboard analog and digital I/O was also critical in providing an efficient solution, as in addition to controlling the servo motor axes that manage the core manufacturing cell functions such as coil winding, the control loops all rely on fast I/O processing to sense and react to events.

The high level keywords and the macro facilities of the Mint language helped to speed implementation of the motion control system. Alliance Winding devised a number of macros which condense sophisticated operations into friendly single commands - helping to reduce the complexity of the control problem, by simplifying coding, debug and optimization.

In total, eight types of cells are used in this application: 'shed' winders for

creating the wire coils on forms (there are six on the machine), plus stations for welding stator laminations, inserting the coils into the laminations, lead placement (manually performed), lead crimping, continuity testing, wire bonding, and fitting the motor housing.

Application:

78-axis production/handling line

Motion controller:

NextMove-PCI, Mint software

Key design advantages:

One card solution for servo axes & actuator/sensor I/O
'Canned' software and macro capability for key tasks

Intelligent stepper drive - it's a one card solution!

This MintMT-compatible intelligent three-axis drive for stepper motors provides an extremely economic solution for applications such as pick-and-place machinery and XYZ positioning tables. Application versatility is further boosted by the ability to control a fourth external stepper motor drive - for associated automation tasks such as materials feed and product positioning.

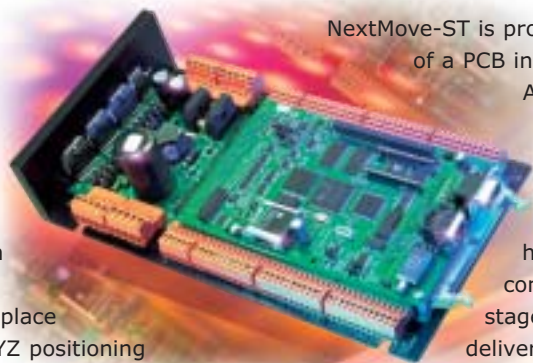

NextMove-ST is provided in the form of a PCB incorporating its own AC-DC power supply for simple integration. Each stepper axis is capable of half-stepping control, with a power stage capable of delivering 2A at 40V. If higher powers are required, stepper control signals can be routed to external drives.

Onboard I/O allows users to employ the module for machine control as well -

eliminating the need for a PLC. I/O may be expanded easily by means of the board's CANopen-compatible port.

A 120MHz 32-bit floating point DSP core provides the speed to support its use in high performance systems, including interpolated moves, and a 100-deep move buffer to optimize execution speed. Programming the TMS320VC33 core in C allows NextMove-ST's stepper moves to be customized to suit specialized requirements or motion profiles. This flexibility is further enhanced by use of FPGA logic, effectively providing an application-specific motion control solution at an off-the-shelf price. e-mail: nextmovest@baldor.co.uk

Linear motor solutions: off the shelf

In addition to our range of linear motors, Baldor has released two tried and tested assemblies to speed and simplify building of high throughput precision positioning systems:

XYZ gantry - LSG provides a ready-built XYZ gantry offering move speeds of up to 3 meters/sec (9.8 ft/sec) and resolutions to 0.1 micron, the assembly provides a short-cut to the realization of the benefits of linear motors for machinery and automation OEMs in markets including electronics, semiconductors and fibre optics. The new gantry can be provided in a range of sizes for working areas of up to 2 x 1.5 meters (6.6 x 4.9 ft) with Z axis travels of up to 25 cm/1 ft, with the capability to handle payloads of up to 23 kg/51 lbs. Based on cog-free brushless AC motors for ultra-smooth movement, the gantry's key



mechanical specifications include move speeds of up to 3 metres/sec (9.8 ft), 0.1 μm resolution, 5 μm repeatability, and 5 millisecond settling times. This combination of speed and accuracy is far superior to that typically achievable with rotary-based positioning components such as ball-screws and belts etc, and additionally provides these benefits within a much smaller physical area. This allows OEMs to build equipment with much shorter cycle times for increased

productivity and throughput, with smaller footprint - a feature that is particularly important for clean room applications.

Linear 'piezo' stage NanoStepper is a positioning stage with a difference. By

incorporating a combination of linear stepper and piezo-friction motors for coarse and fine moves, the stage will make rapid movements across very large working areas, to resolutions of <10 nm. It's also been engineered for an extremely low profile, and is less than 32 mm/1.25 inches high.

This unique product is targeted at improving productivity in areas such as semiconductor probing/test and manufacturing, and fiber optics. For details e-mail: linearstage@baldor.com



A fresh approach to motion programming

The latest Mint motion system development environment supports the evolving needs of machinery and automation customers. It now incorporates license-free multi-tasking, as well as more high level commands for common applications to speed time to market.

Multi-tasking addresses the need to reduce time to market, and manage escalating equipment complexity in the

form of demand for more features such as graphical user interfaces, fieldbus and factory networking, and sophisticated safety mechanisms. MintMT's multi-tasking kernel allows developers to split control software into modules, reducing complexity and allows several programmers to work simultaneously.

Advanced software principles are employed to give users further advantages. These include a common API for Baldor's range of motion control hardware - a feature providing a universal interface which will appeal particularly to OEMs, who are now able to switch with ease between different motion controllers to optimize the cost and performance of different products.

Another important feature for software developers is the introduction of a browser-like file window called Program Navigator in the programmer's 'workbench'. This provides a simple tree structured display of the program's sub routines, events, tasks etc - greatly aiding comprehension, navigation, debugging and maintenance.

MintMT supports an extremely wide range of motion control tasks and needs

- from small machine builders and automation engineers with limited programming experience, to large OEMs with their own expert motion know-how. At one extreme for example, users can write a few lines of code (using the native Basic-like commands - the syntax of which has been reworked to conform closely with the hugely popular Visual Basic), and then run and optimize them within minutes. This type of user is aided by powerful ready-to-use software for motion control, in the form of keywords for common movement tasks such as feed-to-length and flying-shear. At the other end of the spectrum, advanced programs can be developed by means of a Mint-compatible library which may be called from popular Windows development environments and embedded in the controller, or called as required from a host such as a PC. Baldor additionally offers an 'open architecture' interface. This provides a facility for users to define or customize the servo control algorithm and motion profiles - to extract ultimate performance from an off-the-shelf, general-purpose, motion controller. The software is free: www.baldor.co.uk

Motion software boosts world's largest flatbed cutter

Application:

Dynamic orientation of cutter

Motion controller:

NextMove-PCI, Mint software

Key design advantages:

One card solution for servo axes & actuator/sensor I/O
Active-X controls for interfacing
'Canned' software for knife movement

controller card plugged into the system's host PC.

The motion controller provides a compact single-card solution for the machine's cutting movements, controlling two X-Y servo motor axes that move the gantry with its cutting head across and along the flatbed cutting table, plus a third axis to orient the edge of the blade as required. This motion system works autonomously,



The cutting machinery OEM Blackman & White has produced the largest flatbed cutter ever constructed, to cut very long fabric panels for a new type of cargo airship. The cutter employs an innovative knife tool which automatically orients the blade as it moves through fabric - allowing it to generate complex shapes in an environmentally friendly fashion, without the dust or fume by-products of alternative technologies. Flexible motion control software to support the complex real-time rotation of the blade while cutting at speeds up to 2 meters/sec (6.6 ft/sec) is generated by the Mint language, running on a NextMove-PCI motion

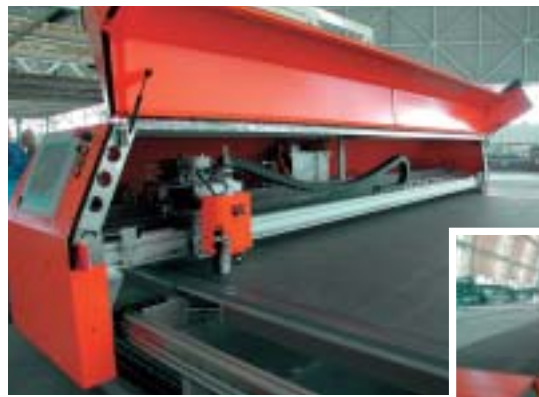

generating all the real-time positional calculations and servo motor signals, once cutting instructions and operational commands are entered on the machine's

human-machine interface with its Visual Basic screens.

The controller's built-in Mint motion language held the key to simple development for this application, as it allows high level 'keywords' to be generated for special applications. In this instance, Baldor generated commands which automatically keep the blade at a tangent to the direction of the X-Y axes. In conjunction with Mint's support for ActiveX - which simplified the interfacing between the host PC and the motion control subsystem - Blackman & White was able to prototype the basic motion control system in just two weeks, helping it to produce this unique machine to tight timescales.



NextMove-PCI is a half-size PCI card which plugs directly into the host PC's expansion bus. This PC is mounted inside the gantry which tracks along the flatbed by means of a rack and pinion - simplifying cabling. In this particular project, because of the extreme lengths of the fabric panels required, four gantries are used, each covering a length of around 60 meters (197 ft), at which point the cutting profile is taken over by the next element. As the controlling PC is housed within the gantry, size and weight of the motion controller were important selection criteria. The NextMove card helped to simplify this aspect of the design because it also included enough onboard I/O to handle the system requirements for this application, including the sensors which monitor the suction system used to hold the fabric steady on the work surface, safety sensors, and the solenoid valve actuator for controlling the knife.

Series II - definitely not a 'me too'

continued from page 1: The new FlexDrive^{II}, Flex+Drive^{II} and MintDrive^{II} provide a

family of brushless AC servo motor controls sharing these features:

- common pin-outs
- common package sizes
- common current ratings
- common hardware configuration/expansion system

FlexDrive^{II} is a single-axis digital drive offering a standard $\pm 10V$ input, or pulse and direction for stepper replacement or master encoder input for gearing applications. Flex+Drive^{II} adds onboard Mint motion control capability for 16 preset positions or speeds (or optionally 256). MintDrive^{II} integrates a fully-featured Mint motion

controller to support advanced requirements with sophisticated motion, HMI and PLC tasks.

Three forms of user-specified, factory-fitted hardware expansion/configuration are available: all three drives accept a feedback configuration module which configures the interface for resolver, encoder or 'Endat' (absolute) signals. All three also accept a similar fieldbus interface module providing CANopen, DeviceNet or Profibus-DP communications. Flex+Drive^{II} and MintDrive^{II} also accept one further option: onboard I/O may be expanded with an additional 15 digital I/Os. For a free brochure in English, Italian, French, German or Spanish, access www.baldor.co.uk/mintnews/index2.html

Flow-wrapper upgrade speeded by multi-tasking software

continues from page 1: Baldor's role was to provide a motion control subsystem to transfer and carton the flow-wrapped chocolate bars. Three servo axes are employed for this. One controls a 'paddle' which sweeps bars through 90 degrees into a flighted conveyor. Two further axes collate bars into groups on a feedchain, and then actuate paddles which transfer the group into a 'lowerator' - simultaneously moving the lowerator on a step for depositing the group into a carton. The system is controlled by the Mint-compatible NextMove-BX, a standalone motion controller which comes with I/O, allowing it to also handle the various sensors in this application.

Development time was greatly reduced by means of Mint's multi-tasking capability. Baldor used this to divide the transfer and cartoning process into five tasks: start paddles, stop paddles (for rejects), feed feedchain, lower lowerator, and manage the man-machine interface. These tasks were then worked on in parallel, by several application engineers, allowing a software prototype to be written and trialed in less than a week. The design was then optimized and integrated with the hardware - including three BSM

brushless AC servo motors, three FlexDrives, a NextMove BX motion controller and various sensors - and delivered for commissioning.

The availability of ready-to-use application software played a key role in Baldor's rapid turnaround of the transfer and cartoning system. This was simplified by the high level 'keywords' in

Mint, which offer a ready-programmed basis for commonly required movements. Among the keywords used in this project were members of the FOLLOW group to control the sweep paddle and feedchain axis; these provided the motion profiles required, but synchronized to a master position rather than a clock.

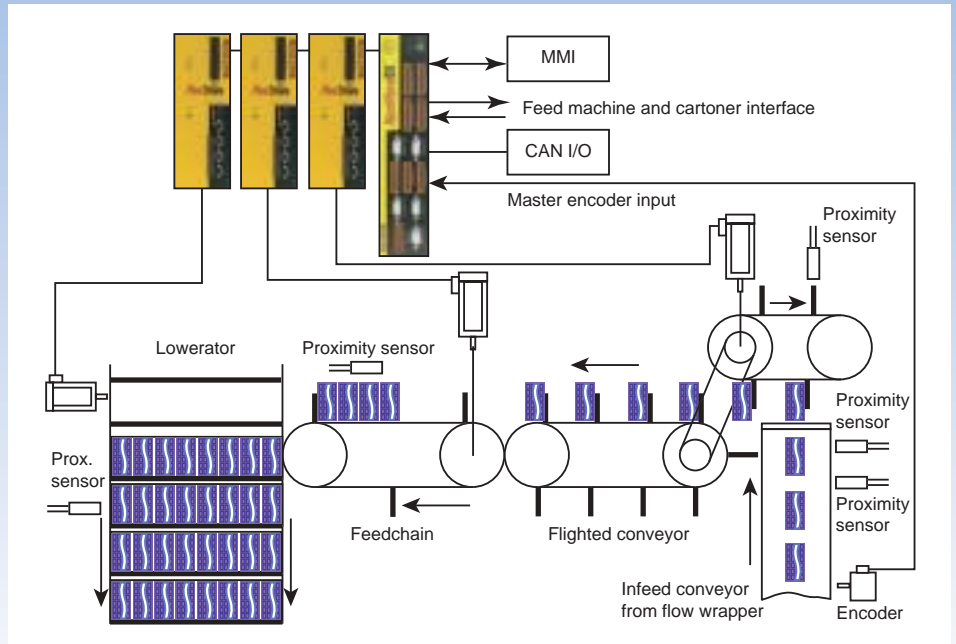

The NextMove-BX motion controller uses multi-tasking software to control three servo axes and the HMI on this chocolate flow wrapping and cartoning machine.

DC deluxe

Two new digital DC drives have been added to Baldor's range, featuring simple English-language keypad control programs for a wide range of constant torque, constant power and precision speed applications. These include hoists, cranes, elevators, conveyors, carriage drives, extruders, veneer lathes, converting and textile machinery, and antennae drives and machine tool spindle drives.

Series 29 SCR drives provide single-quadrant control with options from 5 to 300 HP/3.7 to 223 kW, 198-550 VAC, and three-phase 50/60 Hz supplies. With protected chassis enclosures, selectable



feedback via option boards, auto-tuning, and generous peak overload capacities - the drives are truly versatile and provide a very easy way to realize the benefits of DC motors.

The companion Series 30, adds four-quadrant line-regenerative control, making them ideal wherever regenerated energy is evident due to overhauling loads. Built-in application programs such as a 4-corner S-curve for lifting, and electronic speed

potentiometer for simple variable speed control, assure users of easy installation.

And don't forget that Baldor can also provide complete solutions, with matched motors - typically from stock. e-mail: dcdrives@baldor.com for a brochure.

Lighten up

Baldor has launched a range of Aluminium IEC-frame AC motors, providing cost savings compared with cast iron frame alternatives. Spanning the 0.11 to 7.5kW power range, the range is CE-approved but can be optionally specified to meet UL and CSA standards - simplifying life for international equipment exporters. A large inventory is available for immediate shipment from Baldor's European and American warehouses.

The new motors feature a totally-enclosed, fan-cooled (TEFC) construction. e-mail: iecmotors@baldor.com for a brochure.

Motion control: what's happening

The automation market has declined, but there are still bright spots in the motion control sector. Mark Crocker of Baldor shares his views.

The motion controller business splits readily into hardware typically supplied in PCB form for OEMs - which demand sophisticated software support - and ready-to-use (boxed) products which are ideal for small-to-medium quantity applications. The OEM segment has been particularly badly hit with a double digit decline. This is mainly a result of the general turndown in electronics and semiconductors - which in turn has as its root a significant decline in mobile phones - and the general lack of confidence following September 11.

In contrast, the 'standalone' sector which covers boxed/panel-mounting ready-to-use motion controllers, saw a much smaller decline. This market is particularly broad, which partially accounts for its greater resilience, and ranges from in-house engineers (across all end-user industries) implementing automation, to small-to-medium volume machinery OEMs. This market shrunk primarily as a result of lower confidence. What's typically happening is that projects are being postponed until the outlook looks more promising.

However, one of the interesting side-effects of this general scenario is that many OEMs are typically looking to extend the lifecycles of machine designs, and are keen on any upgrade that reduces costs - benefiting the sub-sector of intelligent drives. This market segment is polarized between simpler drives which include only simple 'positioning' tasks - and products offering a full-featured motion controller. This latter segment is particularly driving growth (Baldor has recently released three new products in this area: Flex+Drive[™], MintDrive[™], and NextMove-ST).

Technology trends

In the current climate, there is little evidence of major shifts in motion controller technology. Motion suppliers are

mainly engaged in cost-reduction projects with customers. However, some trends are apparent. Perhaps the most significant is the increased use of fieldbuses.

Another coincident trend is the rise of high speed serial/networking technologies such as USB and Ethernet. These could result in a considerable reshaping of the OEM segment of the industry in due course. The scenario is that ultimately OEMs can dispense with motion controllers offered in the form of plug-in bus cards for PCs, in favor of serially-connected devices, which are able to run fieldbus protocols over, say, Ethernet.

However, it is almost certainly in the realm of software that the motion control market will undergo its most significant, if least obvious, shift. The demand on automation designers for increased functionality is rising rapidly. For users of boxed ready-to-go products, this is already resulting in more sophisticated motion control - increasingly with growing levels of 'canned software'. For the OEM market, the demand is for tool suites that simplify projects, and cut time to market, using techniques such as multi-tasking and Wizards.



Mark Crocker is head of marketing at Baldor's motion control HQ in Bristol, UK, and may be contacted via mark.crocker@baldor.co.uk

FAQs on Mint

Here's a selection of information about Mint and Mint controllers that our applications team have provided recently:

Q. Can I auto download my application to NextMove PCI on power up? The NextMove PCI wizard (auto initialization utility) can be used to download .MEX (Mint EXecutable files) files and firmware. If you have installed Workbench v5, this utility can be found under the Windows start menu, Programs - 'Workbench v5' - "NextMove PCI Wizard". Note: a .MEX file is created by choosing the 'compile to file' option from Workbench v5 to compile your MintMT program.

Q. Can I use MintMT on a Series I NextMove BX? Yes, just download the code from www.supportme.net and use Workbench v5 to download firmware. To install the firmware start a 'New project', 'Scan' for the controller, choose 'Controller with no firmware' and download from file.

Q. Can I protect MintMT programs from being copied? As default the source file is downloaded to the controller as a backup, but you can disable this from the 'Tools' menu: select 'Options', 'Program Settings' and deselect the 'Always save Mint Source on controller' option. Then, the compiled code cannot be read back or copied.

Q. Is it possible to use binary numbers within MintMT? Yes. To use a binary representation, simply prefix the number with a leading zero, for example: myVariable = IN.0 And 01111. This would read the value of input bank zero, and mask off the upper 4 bits, placing the result into myVariable.

Q. Can I display the value of variables and arrays while a MintMT program runs? The latest Workbench (v5026 and above) has an integrated watch window. Select the Watch window tab, click 'Add' and type in the name of the variable or array name. You can select the update rate and see your variable update automatically.

DID YOU KNOW?

Naming I/O etc: You can use Mint's DEFINE keyword to assign names to inputs, outputs, comms locations and more - making your code more readable and simplifying reallocation of I/O to one line change, for example:

```
DEFINE _ipStartPushButton = INX.0
DEFINE _opSwitchRunLamp = OUTX.1
```

Use of these in the program might then look something like...

```
If _ipStartPushButton = _on THEN
    _opSwitchRunLamp = _on
End If
```

Help on keywords: You can get context-sensitive help within Workbench v5 at any time. Simply place the cursor on the keyword you are interested in and hit F1. You will immediately see all the information on that keyword and associated keywords.

MintMT execution speed: Did you know that MintMT is more efficient than previous versions of Mint? On NextMove PCI, MT runs around 33% faster than v4, and on NextMove BX it is 20% faster. As a comparison NextMove BX runs around 7 times faster than SmartMove.

NEMA answers in non-NEMA regions

Baldor's position as the leading manufacturer of NEMA electric motors means that every year we answer thousands of queries from automation OEMs looking to build or customize products for American and related markets - or to repair US-originated equipment.

The issues we deal with are wide ranging, but understanding minimum efficiency requirements is a common topic at the moment. NEMA recently introduced standards formalizing new minimum efficiency levels required to label a motor as offering 'standard' levels (known as Energy Efficient) or premium (Premium Efficient) levels. (Both these standards are actually superior to those demanded by the US's 1992 EPACK law - which, incidentally, still causes problems for some exporters.) There have also been recent changes to specifications for conduit box sizes.

For an introduction, Baldor publishes handy pocket-sized

guides to NEMA electrical and mechanical specifications.

For free copies, e-mail: nema@baldor.com

However, with engineering time at a premium, don't forget that Baldor's network of European support offices is always happy to answer queries on NEMA motor specifications, and even to involve our US-based engineering teams or representatives who sit on NEMA committees - for complex problems. Call any of the phone numbers shown right to discuss an application.

Baldor maintains a large stock profile of around 500 popular choices - spanning 1/4 to 30HP ratings - at its European warehouse. Why not get a copy of Baldor's interactive or printed catalog? See below.



Baldor was recognized in a recent report by the Consortium for Energy Efficiency, for the performance of its Super E® premium efficient motors.

For the fourth year, Baldor is the only manufacturer with 100% compliance on TEFC and ODP motors that meet or exceed NEMA Premium™ criteria.

FREE LITERATURE:

Motion control compendium. Covering the spectrum of products for this application sector, combined with helpful 'how to' notes including guides to sizing servo and linear motors and specifying different drive arrangements, our 366-page 'BR1202' guide is a valuable addition to the data shelf. e-mail: 1202@baldor.com

Series II drives. (choice of 5 languages): access www.baldor.co.uk/mintnews/index2.html

DC motors - ex-stock. Baldor holds extensive European stocks of DC motors, with 1000s of options spanning permanent magnet and shunt wound construction, IEC and NEMA frames, and IP54, washdown and stainless steel materials. For a guide, e-mail: dcmotors@baldor.co.uk

NEMA motors - the definitive source. Renowned as the leader in NEMA motors, Baldor's '501' stock product catalog details thousands of UL- and CSA-approved products in every industrial duty category (and IEC motors too). It's a definitive guide. e-mail: 501@baldor.com

Interactive motors and drives selector. Baldor's CD-ROM catalog is now at Version 8. Product information includes performance and test data, dimension drawings, nameplate data, replacement parts and installation and operating manuals. Also included is an energy savings analysis program. e-mail: cd8@baldor.com

Aluminium frame IEC motors brochure. e-mail: iecmotors@baldor.com

Linear motors catalog. e-mail: linearstage@baldor.com

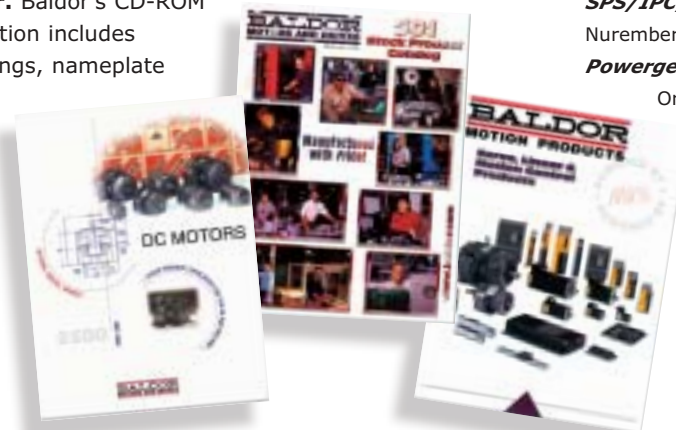

More information?

Motors: www.baldor.com
Motion control: www.baldor.co.uk
Motion controller data, manuals: www.supportme.net

USA and Canada: Baldor Electric Company
T: +1 (0) 479 646-4711
F: +1 (0) 479 648-5792
E: sales@baldor.com

Germany: Baldor ASR GmbH
T: +49 (0) 89 905 08-0
F: +49 (0) 89 905 08-491
E: sales@baldor.de

Switzerland: Baldor ASR AG
T: +41 52 647 4700
F: +41 52 659 2394
E: sales@baldor.ch

UK: Baldor UK Ltd
T: +44 (0) 1454 850000
F: +44 (0) 1454 859001
E: sales@baldor.co.uk

Australia: Australian Baldor PTY. Ltd.
T: +61 2 9674 5455
F: +61 2 9674 2495
E: ray_harding@baldor.com

Singapore: Baldor Electric PTE. Ltd.
T: +65 744 2572
F: +65 747 1708
E: baldorsg@singnet.com.sg

BALDOR

MOTION PRODUCTS

© Baldor 2002. Mint and NanoMove are trademarks of Baldor; all trade names and marks are recognized and are the property of their respective owners. Technical specifications are subject to change.

Meet Baldor ...

... at the following trade shows:

2002

Automate

Melbourne/Australia Oct. 15-17

Sunbelt Agri Show

Moultry/USA, Oct. 15-17

Power Transmission & Control Asia

Pudong/China, Oct. 15-18

Pack Expo

Chicago/USA Nov. 3-7

SPS/IPC/Drives

Nuremberg/Germany, Nov. 26-28

Powergen

Orlando/USA, Dec. 10-12

2003

AHR Expo

Chicago/USA, Jan. 27-30

CMM International

Chicago/USA, Apr. 14-17